

Oles Honchar Dnipro National University

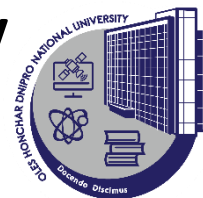

**THE MODERN THEORY
OF AUTOMATIC CONTROL**

**Professor Olexandr PETRENKO
UKRAINE**

DNU – 2023

Contents

Introduction.....	4
Topic 1. Control systems design in the space of state variables.....	6
1.1 General model for describing the automatic control systems in the space of state variables, taking into account the action of uncontrolled random disturbances.....	6
1.2 The concept of controllability of a linear dynamical system. Controllability criterion.....	8
1.3 Solution of the problem of modal control.....	9
1.4 Determination of the feedback matrix, which provides full compensation for the influence of disturbances on the vector of the system output variables.....	11
1.5 Recommendations for choosing the desired characteristic polynomial of a closed system.....	12
1.6 Solution of the problem of analytical design of the optimal controller. Riccati equation.....	15
1.7 Determination of a mathematical model of uncontrolled random disturbances acting on the system.....	17
1.8 Example.	
Topic 2. Application of the observers in the control systems.....	20
2.1 Necessity of an observing device using in structure of the closed control system.....	20
2.2 The concept of observability of a linear dynamical system. Observability criterion.....	21
2.3 Example of the simplest observing device.....	22
2.4 The asymptotic observing devise.....	23
2.5 The extended observing devise.....	25
2.6 Results of digital modeling of a system closed in terms of the state vector.....	27
2.7 Modeling the processes of estimating the state vector of the system by the asymptotic observer.....	29
2.8 Modeling the process of estimating random disturbances	

acting on the control object.....	31
2.9 Simulation of the closed system operation under the action of random disturbances.....	33
References.....	35

Introduction

Modern automatic control systems that are used in energy, transport, aviation, and space technology differ significantly from those simple systems for which the classical theory of automatic control was developed.

For comparison, consider the main features of classical and modern automatic control theory.

Classic theory of automatic control:

Application area – one-dimensions, linear, dynamics systems.

Mathematical apparatus:

➤ Linear differential equations.

➤ Laplace transforming $F(s) = L\{f(t)\} = \int_0^{\infty} e^{-st} f(t) dt$,

where s – Laplace's variable.

➤ Transfer functions $W(s) = M_m(s)/N_n(s)$, m – nominator order, n – denominator order, $n > m$.

➤ $N_n(s)$ – characteristics polynomial of system.

➤ Frequency characteristics - $A(\omega)$, $\varphi(\omega)$, $W(j\omega)$.

➤ application of standard links of automatic control systems.

Tasks to be solved:

➤ Determination of the stability of automatic control systems;

➤ the use of algebraic (Hurwitz, Routh) and frequency (Mikhailov, Nyquist-Mikhailov) stability criteria;

➤ determination of the transfer function of the system by the control and disturbing influences;

➤ creation of transient processes of the system.

Description of systems in the space of state variables:

The field of application:

The analysis and synthesis of multidimensional, linear, dynamic systems operating under conditions of uncontrolled random disturbances.

Mathematical apparatus:

- Systems of differential equations.
- Matrix differential equations.
- Matrix calculations.
- The use of the concepts of controllability and observability.

Tasks to be solved:

- Analysis of the system: does the system have the property of complete controllability and complete observability;
- System synthesis: a) solving the problem of modal control; b) solving the problem of analytical design of the optimal controller;
- Creation of the mathematical models of uncontrolled random perturbations in the state space;
- Construction of an observing device that provides an estimate of the state vector of the system;
- Creation of an extended observing device that provides an estimate of the state vector of the system and also an estimate of the vector of uncontrolled random disturbances acting on the system;
- Synthesis of a closed system that provides the given dynamic properties of the system and compensation for uncontrolled random disturbances.

Topic 1. Control systems design in the space of state variables

1.1 General model for describing the automatic control systems in the space of state variables, taking into account the action of uncontrolled random disturbances.

The general model can be represented as follows:

$$\begin{cases} \dot{X}(t) = AX(t) + BU(t) + FW(t) \\ Y(t) = CX(t) \end{cases} \quad (1.1)$$

where $X(t)$ is the object's state vector, fully characterizing the current state of the object's variables;

$Y(t)$ – the vector of object output variables that directly ensure the achievement of the control goal;

$U(t)$ – the vector of control signals applied to the inputs of the control system;

$W(t)$ – vector of uncontrolled random perturbations acting to the system and causing deviation of the vector of output variables $Y(t)$ from the given values;

A, B, C, F – matrices of coefficients of the mathematical model of the object, which can be obtained when solving problems of structural and parametric identification of the control object.

The vector of random disturbances $W(t)$ can be considered as the output of some dynamical system of the form:

$$\begin{cases} \dot{Z}(t) = DZ(t) + \alpha i \Delta i(t - \tau) \\ W(t) = HZ(t) \end{cases} \quad (1.2)$$

where $Z(t)$ is the “state” vector of disturbances acting on the subsystems of the control object;

$W(t)$ – equivalent signal perturbations, which, when applied to the input of the system, cause a corresponding deviation of the vector of output variables $Y(t)$ from the given values;

D, H – matrices of coefficients of the mathematical model of uncontrolled random disturbances, the structure and parameters of which depend on the nature of the disturbances actually acting on the object and can be determined on the basis of experimental studies;

$\alpha_i \Delta I$ – sequence vector of δ -functions with weight coefficients αI changing in a random, piecewise-constant manner at random times.

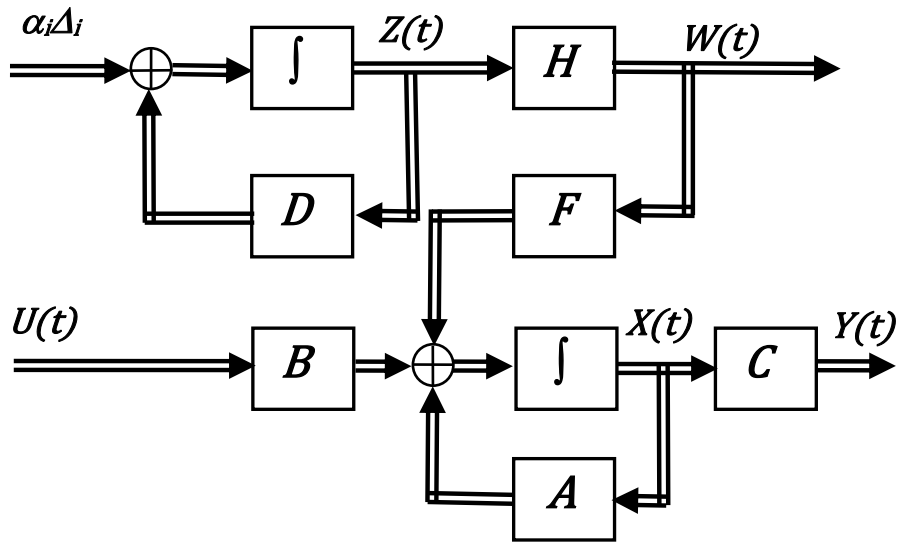

Fig. 1.1. The block diagram of the control object mathematical model

When synthesizing automatic control systems, an important question is whether it is possible, using negative feedback, to obtain the necessary dynamic characteristics of a closed system.

To answer this question, the concept of complete controllability of the system is introduced.

1.2 The concept of controllability of a linear dynamical system. Controllability criterion.

The concept of controllability for system (1.1) consists in answering the question whether it is possible, by introducing feedbacks

$$U(t) = KX(t)$$

provide the required values of all components of the system state vector $X(t)$. This concept is inextricably linked with the possibility of placing the roots of the characteristic equation of the system on the complex plane in a given way by introducing feedbacks.

The criterion for the complete controllability of system (1.1) is the equality of the rank of its controllability matrix Q_c to the order n of the system, i.e., $\text{rank}[Q_c] = n$, where the controllability matrix is defined as follows:

$$Q_c = [B, AB, A^2B, \dots, A^{n-1}B]. \quad (1.3)$$

1.3 Solution of the problem of modal control.

The synthesis of an automatic control system based on the solution of **the modal control problem** is to implement the control law of the following form:

$$U(t) = K_1 X(t) + K_2 W(t), \quad (1.4)$$

where K_1 – matrix of feedback coefficients, providing the required placement of the poles of the closed system on the complex plane;

K_2 – a matrix of feedback coefficients that provides full compensation for the influence of random disturbances $W(t)$ on the vector of output variables $Y(t)$.

Since the mathematical models (1.1) and (1.2) are linear approximations, the determination of the numerical values of the elements of the matrices K_1 and K_2 can be determined independently.

The block diagram of a closed system in which a control law of the form (1.4) is implemented has the form, as shown in Fig. 1.2.

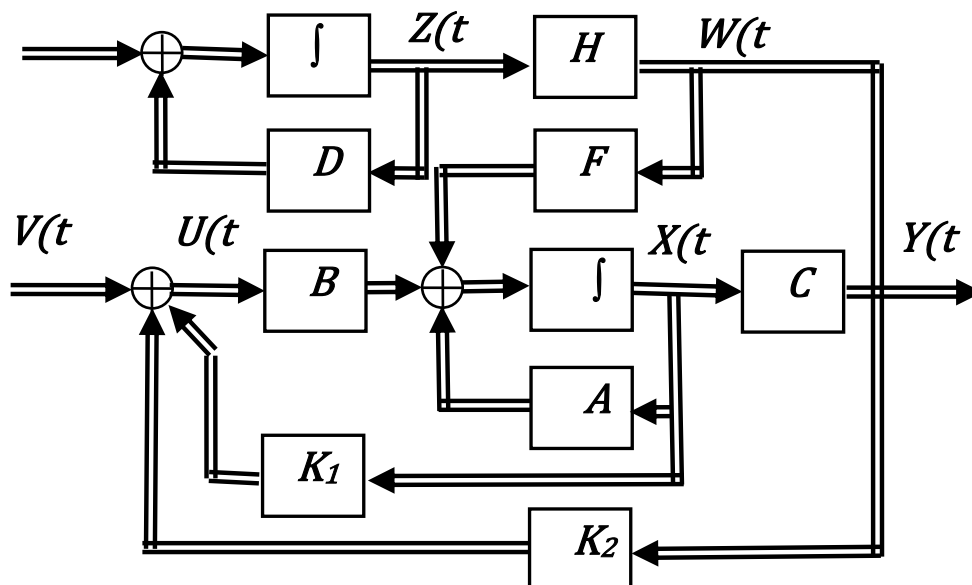

Fig. 1.2. The block diagram of a closed system

To determine the elements of the feedback matrix K_I when solving the problem of modal control, it is necessary to write the equation of a closed system for the form (1.1) taking into account the control law (1.4) in such form

$$\dot{X}(t) = [A + BK_1][X(t)]. \quad (1.5)$$

When solving the problem of modal control by choosing the feedback matrix of the system K_I , you can get any desired placement of the closed system poles on the complex plane.

To determine the numerical values of the elements of the feedback matrix K_I , it is necessary to equate the characteristic polynomial corresponding to the closed system equation (1.5) to some desired characteristic polynomial

$$\mathbf{det}[sI - A - BK_1] = \varphi_d(s), \quad (1.6)$$

where s – the Laplace variable; I – identity matrix;

$\varphi_d(s)$ – the desired characteristic polynomial of the closed system.

Setting the distance of closed system poles removal on the complex plane from the imaginary axis ω_0 , and also choosing various forms of the desired closed system characteristic polynomials, from (1.6) we obtain a system of algebraic equations for determining the numerical values of the elements of the feedback matrix K_I .

This problem is solved unambiguously only for systems with one input, and the problem of choosing of the desired characteristic polynomial $\varphi_d(s)$ is difficult to formalize and depend on the qualifications of the system developers.

1.4 Determination of the feedback matrix, which provides full compensation for the influence of disturbances on the vector of the system output variables.

To determine the matrix of feedback K_2 , which provides full compensation for the effect of disturbances $W(t)$ on the vector of the system output variables, we can write the solution of the equations (1.1) in the form

$$Y(t) = Ce^{A(t-t_0)}X_0 + C \int [e^{A(t-\tau)}BU(\tau) + FHZ(\tau)]d\tau. \quad (1.7)$$

In order for uncontrolled random perturbations $W(t)$ acting on the system not to affect the vector of output variables $Y(t)$, it is necessary and sufficient that the second term in (1.7) be equal to zero. This can be achieved if there is such a matrix K_2 , for which the condition will be satisfied:

$$Ce^{A(t-\tau)}BK_2 + FH = 0,$$

whence we obtain that the matrix K_2 must satisfy the following condition:

$$BK_2 + FH = 0. \quad (1.8)$$

Thus, the matrix K_2 can be determined if the numerical values of the matrices B , F , H are known.

1.5 Recommendations for choosing the desired characteristic polynomial of a closed system.

As one of the typical characteristic polynomials of a system with an aperiodic nature of the transient process, it is proposed to use a characteristic polynomial with binomial coefficients:

$$N(p) = (p + \omega_0)^n, \quad (1.9)$$

where ω_0 is the distance of the characteristic polynomial roots removal from the imaginary axis on the complex plane; n is the order of the system.

One of the possible indicators of the quality of the transition function $h(t)$ can be its deviation from the ideal step function $1(t)$, which can be estimated by the integral

$$I = \int_0^{\infty} [1(t) - h(t)]^2 dt. \quad (1.10)$$

The characteristic polynomials that ensure the minimum of the squared error integral (1.10) have the form

$$N_2(p) = p^2 + \omega_0 p + \omega_0^2$$

$$N_3(p) = p^3 + \omega_0 p^2 + 2\omega_0^2 p + \omega_0^3$$

$$N_4(p) = p^4 + \omega_0 p^3 + 3\omega_0^2 p^2 + 2\omega_0^3 p + \omega_0^4$$

$$N_5(p) = p^5 + \omega_0 p^4 + 4\omega_0^2 p^3 + 3\omega_0^3 p^2 + 3\omega_0^4 p + \omega_0^5 \quad (1.11)$$

$$N_6(p) = p^6 + \omega_0 p^5 + 5\omega_0^2 p^4 + 4\omega_0^3 p^3 + 6\omega_0^4 p^2 + 3\omega_0^5 p + \omega_0^6$$

$$N_7(p) = p^7 + \omega_0 p^6 + 6\omega_0^2 p^5 + 5\omega_0^3 p^4 + 10\omega_0^4 p^3 + 6\omega_0^5 p^2 + 4\omega_0^6 p + \omega_0^7$$

$$N_8(p) = p^8 + \omega_0 p^7 + 7\omega_0^2 p^6 + 6\omega_0^3 p^5 + 15\omega_0^4 p^4 + 10\omega_0^5 p^3 + 10\omega_0^6 p^2 + 4\omega_0^7 p + \omega_0^8$$

If the indicator of the quality of the transient process is the minimum of the integral of the weighted error modulus

$$I = \int_0^{\infty} t|1(t) - h(t)|dt \quad (1.12)$$

then typical characteristic polynomials have the following forms:

$$N_2(p) = p^2 + 1,41\omega_0 p + \omega_0^2$$

$$N_3(p) = p^3 + 1,75\omega_0 p^2 + 2,15\omega_0^2 p + \omega_0^3$$

$$N_4(p) = p^4 + 2,10\omega_0 p^3 + 3,40\omega_0^2 p^2 + 2,70\omega_0^3 p + \omega_0^4$$

$$N_5(p) = p^5 + 2,80\omega_0 p^4 + 5,0\omega_0^2 p^3 + 5,5\omega_0^3 p^2 + 3,4\omega_0^4 p + \omega_0^5$$

$$N_6(p) = p^6 + 3,25\omega_0 p^5 + 6,6\omega_0^2 p^4 + 8,6\omega_0^3 p^3 + 7,45\omega_0^4 p^2 + 3,95\omega_0^5 p + \omega_0^6 \quad (1.13)$$

$$N_7(p) = p^7 + 4,47\omega_0 p^6 + 10,24\omega_0^2 p^5 + 15,08\omega_0^3 p^4 + 15,54\omega_0^4 p^3 + 10,64\omega_0^5 p^2 + 4,58\omega_0^6 p + \omega_0^7$$

$$N_8(p) = p^8 + 5,2\omega_0 p^7 + 12,8\omega_0^2 p^6 + 21,6\omega_0^3 p^5 + 25,75\omega_0^4 p^4 + 22,2\omega_0^5 p^3 + 13,3\omega_0^6 p^2 + 5,15\omega_0^7 p + \omega_0^8$$

Consider another approach to the choice of typical models. From the theory of active filters, it is known that one of the undesirable types of signal distortions are phase distortions, which are the greater, the stronger the phase-frequency characteristic of the system differs from linear. In the theory and practice of active filters, it is shown that Thomson filters have the closest to linear phase-frequency response. The characteristic polynomials of the transfer functions of these filters are Bessel polynomials, therefore such filters are called Bessel-Thomson filters.

The characteristic polynomials of the Bessel-Thomson model have the form:

$$N_2(p) = p^2 + 2,20\omega_0 p + 1,62 \omega_0^2$$

$$N_3(p) = p^3 + 3,42\omega_0 p^2 + 4,87\omega_0^2 p + 2,77 \omega_0^3$$

$$N_4(p) = p^4 + 4,73\omega_0 p^3 + 10,07\omega_0^2 p^2 + 11,12\omega_0^3 p + 5,26 \omega_0^4$$

$$N_5(p) = p^5 + 6,18\omega_0 p^4 + 17,82\omega_0^2 p^3 + 29,37\omega_0^3 p^2 + 27,23\omega_0^4 p + 11,22 \omega_0^5 \quad (1.15)$$

$$N_6(p) = p^6 + 7,77\omega_0 p^5 + 28,74\omega_0^2 p^4 + 63,78\omega_0^3 p^3 + 88,48\omega_0^4 p^2 + 72,0\omega_0^5 p + 26,63 \omega_0^6$$

$$N_7(p) = p^7 + 9,49\omega_0 p^6 + 43,0\omega_0^2 p^5 + 121,83\omega_0^3 p^4 + 228,18\omega_0^4 p^3 + 278,29\omega_0^5 p^2 + 204,27\omega_0^6 p + 69,21\omega_0^7$$

$$N_8(p) = p^8 + 11,3\omega_0 p^7 + 62,10\omega_0^2 p^6 + 214,73\omega_0^3 p^5 + 506,40\omega_0^4 p^4 + 828,27\omega_0^5 p^3 + 912,21\omega_0^6 p^2 + 615,53\omega_0^7 p + 94,08 \omega_0^8$$

Thus, using typical characteristic polynomials of the form (1.9, 1.11, 1.13 - 1.15) when solving the problem of modal control, it is possible to satisfy various requirements for the dynamic characteristics of a system closed in terms of the state vector variables.

**1.6 Solution of the problem of analytical design of the optimal controller.
Riccati equation.**

Under the condition of complete controllability of a linear system of the form (1.1), the roots of the characteristic equation of a closed system can be arbitrarily placed on the complex plane by choosing a feedback matrix K_1 and thus ensure the desired dynamics of a closed system of automatic control.

However, the formal solution of the modal control task causes to a significant increase in the amplitude of control signals. In any practical task of synthesis of a control system, the amplitude of control signals $U(t)$ is limited, which imposes restrictions on the areas of possible placement of the poles of a closed system. Accounting for such a constraint causes to the formulation of the problem of analytical design of the optimal controller, in which the choice of feedback coefficients of the system involves the optimization of the *integral square criterion*, which takes into account both the quality of the transient process and the magnitude of the control signals.

For control objects of the form (1.1), the control law of the form

$$U(t) = K_1(t)X(t)$$

ensures minimization of the integral quadratic criterion of the following form:

$$I = \int_{t_0}^{t_k} X^T(t)Q_1(t)X(t)dt + \int_{t_0}^{t_k} U^T(t)Q_2(t)U(t)dt + X^T(t_k)Q_0X(t_k), \quad (1.16)$$

where $X(t)$ is the system state vector; $U(t)$ – vector of control signals; Q_0, Q_1, Q_2 – given matrices of weight coefficients.

In this case, the matrix of feedback coefficients K_1 is determined as

$$K_1(t) = Q_2^{-1}(t)B^T(t)R(t), \quad (1.17)$$

where $R(t)$ is the solution of the matrix Riccati equation, which has the form

$$\dot{\mathbf{R}}(t) = \mathbf{A}^T(t)\mathbf{R}(t) + \mathbf{R}(t)\mathbf{A}(t) + \mathbf{Q}_1(t) - \mathbf{R}(t)\mathbf{B}(t)\mathbf{Q}_2^{-1}(t)\mathbf{B}^T(t)\mathbf{R}(t) \quad (1.18)$$

with a final condition at the point t_k : $\mathbf{R}(t_k) = \mathbf{Q}_0$.

For stationary systems, the optimal feedback coefficients at $t \rightarrow \infty$ tends to a steady value and expression (1.17) takes the following form:

$$\mathbf{K}_1 = \mathbf{Q}_2^{-1}\mathbf{B}^T\mathbf{R}, \quad (1.19)$$

where \mathbf{R} is a positive-definite solution of the matrix equation following from equation (1.18) and which takes the following form:

$$\mathbf{A}^T\mathbf{R} + \mathbf{R}\mathbf{A} + \mathbf{Q}_1 - \mathbf{R}\mathbf{B}\mathbf{Q}_2^{-1}\mathbf{B}^T\mathbf{R} = \mathbf{0}. \quad (1.20)$$

1.7 Determination of a mathematical model of uncontrolled random disturbances acting on the system.

Uncontrolled random disturbances acting on the system can be represented as a weighted sum of some typical signals, the parameters of which change in a random, piecewise constant manner at random times. Such perturbations can be represented as

$$w(t) = c_1 f_1(t) + c_2 f_2(t) + \dots + c_m f_m(t) \quad (1.21)$$

Random signal (1.21) can be considered as a weighted combination of known basic functions with unknown weight coefficients. If step, linear and quadratic signals are taken as basic functions, then expression (1.21) can be represented as:

$$w(t) = \alpha_1 + \alpha_2 t + \alpha_3 t^2. \quad (1.22)$$

A dynamic model whose output is a polynomial signal (1.22) can be represented as:

$$\begin{cases} \dot{z}_1(t) = z_2(t) + \alpha_1 \cdot \delta_1(t - \tau_1) \\ \dot{z}_2(t) = z_3(t) + \alpha_2 \cdot \delta_2(t - \tau_2) \\ \dot{z}_3(t) = \alpha_3 \cdot \delta_3(t - \tau_3) \end{cases} \quad (1.23)$$

The dynamic model (1.23) can be represented in the matrix form

$$\begin{cases} \dot{\mathbf{Z}}(t) = \mathbf{DZ}(t) + \boldsymbol{\alpha i \Delta i}(t - \boldsymbol{\tau}) \\ \mathbf{W}(t) = \mathbf{HZ}(t) \end{cases},$$

where $\mathbf{Z}(t) = \begin{bmatrix} z_1 \\ z_2 \\ z_3 \end{bmatrix}$ – vector of disturbances states;

$$\mathbf{D} = \begin{bmatrix} 0 & 1 & 0 \\ 0 & 0 & 1 \\ 0 & 0 & 0 \end{bmatrix}; \mathbf{H} = [1 \quad 0 \quad 0] - \text{matrices, the parameters of which are}$$

obtained based on the analysis of uncontrolled random perturbations acting on the control object.

1.8 Example

Let us consider a simple system consisting of aperiodic links of the first and second orders, to the inputs of which control signals u_1 and u_2 are applied, and the output signals of which x_1 and x_3 are summed and fed through the amplifying link to the output y , as shown in Fig. 1.3.

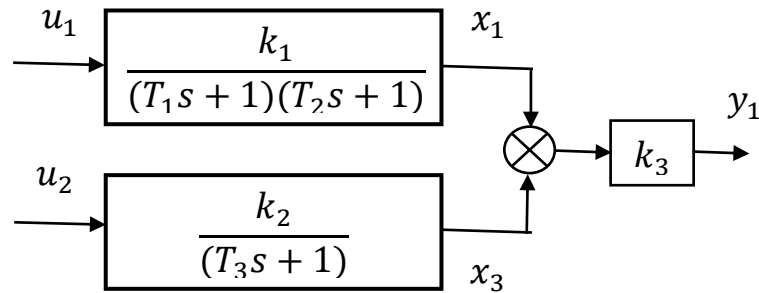

Fig. 1.3. Block scheme of the control object

For the system presented in fig. 1.3 let's write the systems of equations:

$$\begin{cases} T_1 T_2 \ddot{x}_1(t) + (T_1 + T_2) \dot{x}_1(t) + x_1 = k_1 u_1(t) \\ T_3 \dot{x}_3(t) + x_3(t) = k_2 u_2(t) \\ y(t) = k_3 (x_1(t) + x_3(t)) \end{cases} .$$

Transform the resulting system of equations to the form:

$$\begin{cases} \ddot{x}_1(t) = -\frac{T_1+T_2}{T_1 T_2} \dot{x}_1(t) - \frac{1}{T_1 T_2} x_1(t) + \frac{k_1}{T_1 T_2} u_1(t) \\ \dot{x}_3(t) = -\frac{1}{T_3} x_3(t) + \frac{k_2}{T_3} u_2(t) \\ y(t) = k_3 (x_1(t) + x_3(t)) \end{cases} .$$

Introducing the notation $\dot{x}_1(t) = x_2(t)$, we can write:

$$\begin{cases} \dot{x}_1(t) = x_2(t) \\ \dot{x}_2(t) = -\frac{1}{T_1 T_2} x_1(t) - \frac{T_1+T_2}{T_1 T_2} x_2(t) + \frac{k_1}{T_1 T_2} u_1(t) \\ \dot{x}_3(t) = -\frac{1}{T_3} x_3(t) + \frac{k_2}{T_3} u_2(t) \\ y(t) = k_3 (x_1(t) + x_3(t)) \end{cases} .$$

From the resulting system of equations, we obtain the matrices of the mathematical model of the system of the form (1.1):

$$\mathbf{X}(t) = \begin{bmatrix} x_1(t) \\ x_2(t) \\ x_3(t) \end{bmatrix}; \mathbf{A} = \begin{bmatrix} 0 & 1 & 0 \\ a_{21} & a_{22} & 0 \\ 0 & 0 & a_{33} \end{bmatrix}; \mathbf{B} = \begin{bmatrix} 0 & 0 \\ b_{21} & 0 \\ 0 & b_{32} \end{bmatrix};$$

$$\mathbf{C} = [c_{11} \quad 0 \quad c_{13}]$$

where $a_{21} = -\frac{1}{T_1 T_2}$; $a_{22} = -\frac{T_1 + T_2}{T_1 T_2}$; $a_{33} = -\frac{1}{T_3}$; $b_{21} = -\frac{k_1}{T_1 T_2}$; $b_{32} = -\frac{k_2}{T_3}$; $c_{11} = k_3$; $c_{13} = k_3$.

The resulting matrices of the system make it possible to analyze the controllability of the system, solve the problem of modal control and analytical design of the optimal controller.

Topic 2. Application of the observers in the control systems

2.1 Necessity of an observing device using in structure of the closed control system.

Methods for the synthesis of closed systems, based both on solving the problem of modal control and analytical design of optimal controllers, suggest: firstly, the presence of a mathematical model of the control object of the form (1.1) and a model of random perturbations of the form (1.2), and secondly, the assumption of that all components of the vectors $X(t)$ of the object and $Z(t)$ of random perturbations are available for direct measurement. These assumptions underlie the use of a control law of the form (1.4).

For the synthesis of real control systems, it is necessary to have a mathematical model of the object in the form of matrices A, B, C, F , as well as matrices D and H , characterizing the mathematical model of random disturbances. These matrices can be determined as a result of structural and parametric identification based on theoretical and experimental studies of the control object.

As for the measurement of the vectors $X(t)$ and $Z(t)$, these vectors are not available for direct measurement for real technical systems. Therefore, to implement the considered control laws, it is necessary to include ***an observing device*** into the closed system, designed to obtain an estimate of the vectors $X^*(t)$ of the object and an estimate of the vector of random disturbances $Z^*(t)$, which can be used in a control law of the form (1.4).

2.2 The concept of observability of a linear dynamical system. Observability criterion.

In modern control theory, along with the concept of controllability, the concept of **observability** is widely used. If the system has the property of complete observability, then, having mathematical models (1.1), it is possible to construct such a dynamic model (observing device) that will provide an estimate of the state vector of the system $X^*(t)$.

The criterion for complete observability of system (1.1) is the equality of the rank of its observability matrix Q_{obs} to the order n of the system, i.e. $rank[Q_{obs}] = n$, where the observability matrix is defined as follows:

$$Q_{obs} = [C, CA, CA^2, \dots, CA^{n-1}]. \quad (2.1)$$

2.3 Example of the simplest observing device.

If the mathematical model of the control object of the form (1.1) is known, i.e. matrices A , B , C are defined, then a digital or analog model of the system can be considered as the simplest observing device:

$$\begin{cases} \dot{X}^*(t) = AX^*(t) + BU(t) \\ Y^*(t) = CX^*(t) \end{cases} \quad (2.2)$$

to which the same vector of control signals $U(t)$ is applied as to the real object, as shown in Fig. 2.1.

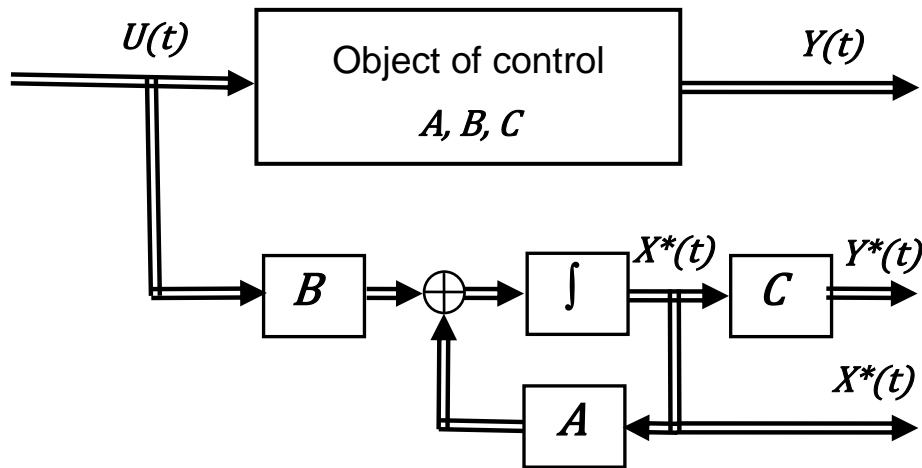

Fig. 2.1. The simplest observing device

Since the observing device contains an exact mathematical model of the control object, the same control signals $U(t)$ are applied to the inputs of the object and the observer, it can be assumed that the state vector of the system $X(t)$ and its estimate at the output of the observing device $X^*(t)$ will coincide.

In reality, these vectors **do not coincide**, because the control object and its mathematical model have **different initial conditions**, therefore, even if an exact mathematical model is used, the vectors $X(t)$ and $X^*(t)$ will not coincide. Therefore, instead of the observing device shown in Fig. 2.1, an **asymptotic observer** is used.

2.4 The asymptotic observing devise.

To ensure that the estimate of the state vector of the system $X^*(t)$ of the observer tends to the state vector of the real system $X(t)$, an asymptotic observer is used. The principle of operation of such an observer is as follows. The vectors of the output variables of the control object $Y(t)$ and the observer $Y^*(t) = CX^*(t)$ are compared, and the magnitude of the signal difference in the form of a negative feedback signal through the matrix L is fed to the observer's input. The mathematical model of the asymptotic observer has the following form:

$$\dot{X}^*(t) = AX^*(t) + BU(t) + L[CY^*(t) - Y(t)], \quad (2.3)$$

where the observer's feedback matrix L ensures tends to $X^*(t) \rightarrow X(t)$.

The block diagram of the asymptotic observer is shown in Fig. 2.2.

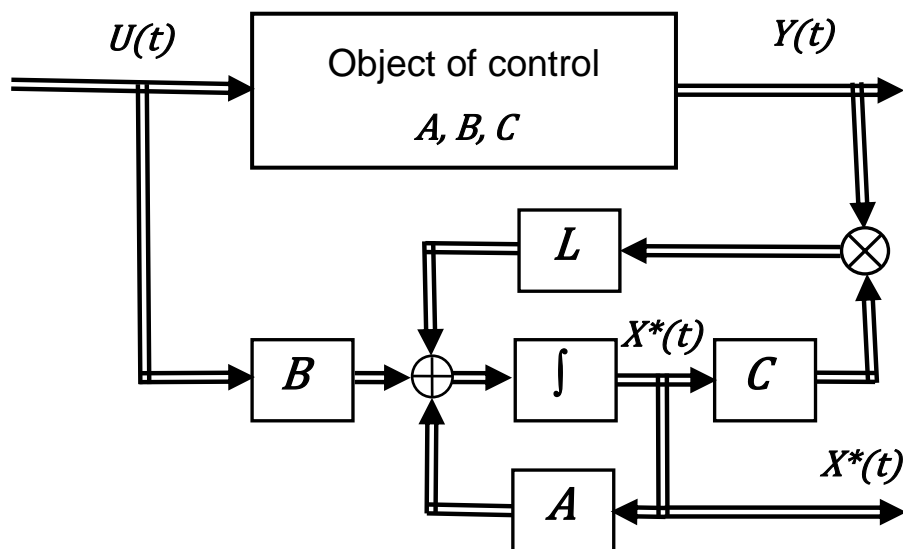

Fig. 2.2. The asymptotic observer block diagram

The observer's feedback matrix L determines the rate of the process of estimating the state vector of the system. Thus, to creation an asymptotic observer, it is necessary to know not only the matrices of the mathematical model of the object A, B, C , but also to determine the values of the elements of the matrix L .

To determine the observer's feedback matrix L , we represent expression (2.3) in the following form:

$$\dot{X}^*(t) = (A+LC)X^*(t) + BU(t) - LY(t). \quad (2.4)$$

It is known that the condition $X^*(t) \rightarrow X(t)$ will be fulfilled if the observer, as a closed dynamical system, is stable.

To determine the numerical values of the elements of the feedback matrix L , it is necessary to equate the characteristic polynomial corresponding to the closed system equation (2.4) to some desired characteristic polynomial

$$\det[sI - A - LC] = \varphi_{\text{ж}}(s), \quad (2.5)$$

where s is the Laplace variable; I - identity matrix.

From expression (2.5) we obtain a system of algebraic equations for obtaining the elements of the matrix L .

We can say that the matrix L of the observer is determined in the same way as the matrix of feedback coefficients K is determined when solving the problem of modal control of a closed system.

Having created an asymptotic observer, the obtained estimates of the state vector of the system $X^*(t)$ can be used in the control law (1.4).

2.5 The extended observing devise.

In the control law (1.4), along with the state vector of the system $X(t)$, the uncontrolled random disturbances, acting to the object of control, $W(t)$ is used, which are also inaccessible for direct measurement. Therefore, along with obtaining an estimate of the state vector of the system $X^*(t)$, it is necessary to obtain an estimate of the uncontrolled random disturbances $W(t)$ acting on the system.

This problem can be solved by constructing an extended observer whose mathematical model has the following form:

$$\begin{bmatrix} \dot{X}^*(t) \\ \dot{Z}^*(t) \end{bmatrix} = \begin{bmatrix} A + L_1 C & FH \\ L_2 C & D \end{bmatrix} \begin{bmatrix} X^*(t) \\ Z^*(t) \end{bmatrix} - \begin{bmatrix} L_1 \\ L_2 \end{bmatrix} Y(t) + \begin{bmatrix} B \\ 0 \end{bmatrix} U(t), \quad (2.6)$$

where L_1, L_2 are the observer's feedback coefficient matrices, which ensure that the estimation error of the object state vector and the state vector of random disturbances tends to zero.

To determine the numerical values of the elements of the unknown feedback matrices L_1 and L_2 of the observer, we write down the characteristic polynomial of the observer and equate it to some desired characteristic polynomial.

The equation for the estimation error of the variables $X(t), Z(t)$ for the observing device has the form:

$$\begin{bmatrix} \dot{e}_x(t) \\ \dot{e}_z(t) \end{bmatrix} = \begin{bmatrix} A + L_1 C & FH \\ L_2 C & D \end{bmatrix} \begin{bmatrix} e_x(t) \\ e_z(t) \end{bmatrix}. \quad (2.7)$$

The characteristic polynomial of the observer in this case solutions, as

$$\varphi_{obs}(s) = \det\left(\begin{bmatrix} A + L_1 C & FH \\ L_2 C & D \end{bmatrix} - sI\right). \quad (2.8)$$

Equating the coefficients of the characteristic polynomial of the observing device (2.8) with the coefficients of some desired characteristic polynomial, we obtain a system of equations for determining the unknown elements of the feedback matrices of the observing device L_1 and L_2 .

The structure of the extended observer and the scheme of its connection to the control object is shown in fig. 2.3.

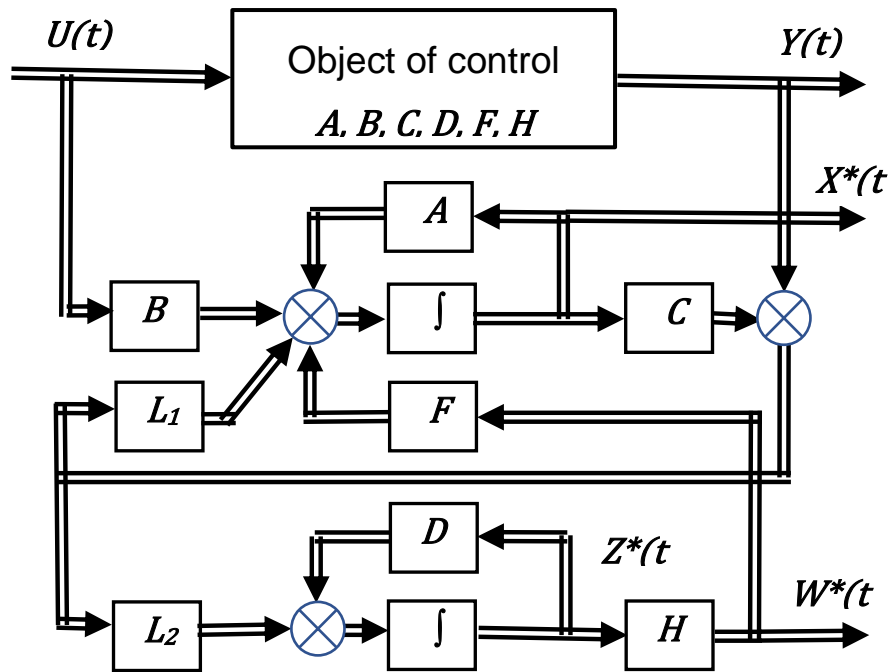

Fig. 2.3. The extended observing devise

2.6 Results of digital modeling of a system closed in terms of the state vector.

When solving the modal control problem described in p.1.3, the matrix K_I is determined taking into account the recommendations for choosing the desired characteristic polynomial presented in p. 1.4.

In the process of modeling the system considered in the example of p. 1.8, elements of the feedback matrix K_I were obtained for the binomial form of the characteristic polynomial, Butterworth and Bessel-Thomson. For each characteristic polynomial, the elements of matrix K_I are obtained for three values of the distance of the closed system poles from the imaginary axis: $q = 4, 8, 20$. The results of digital simulation are shown in Figs. 2.4 - 2.6.

The dynamics of a closed system was estimated from the curve of the transient process of the system from non-zero initial conditions of the variable $x_1(0)$ of the system.

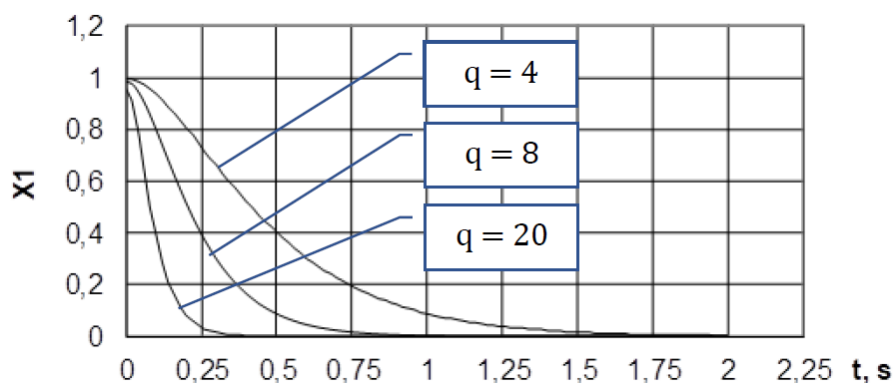

Fig 2.4. Dynamics of the closed system for binomial characteristics polynomial

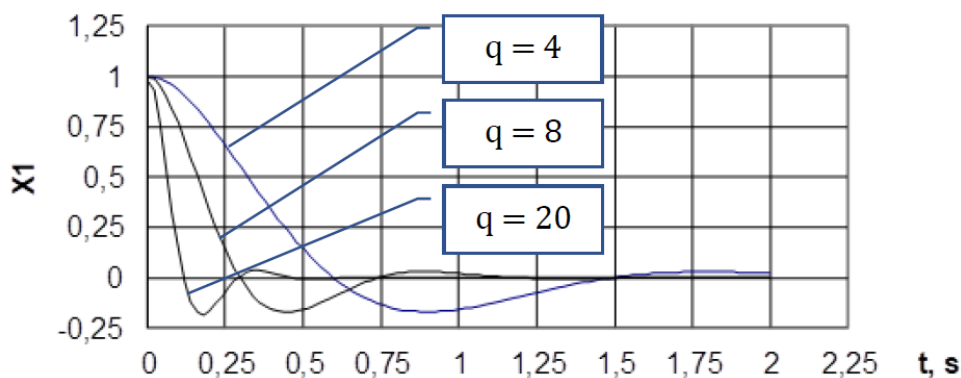

Fig 2.5. Dynamics of the closed system for Butterworth characteristics polynomial

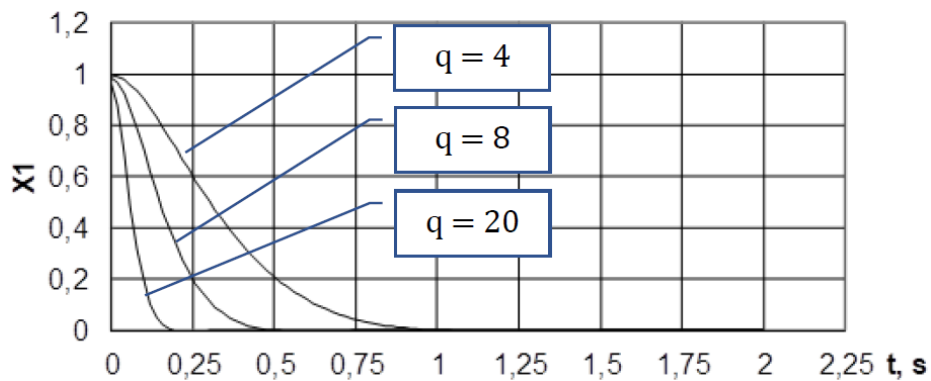

Fig 2.6. Dynamics of the closed system for Bessel-Thomson characteristics polynomial

The simulation results show that, as expected, a closed system with the binomial form of the characteristic polynomial (Fig. 2.4) has a minimum speed.

The system with the Butterworth characteristic polynomial (Fig. 2.5) has a higher speed, but the transient process is oscillatory and overshoot appears.

A closed system with the Bessel-Thomson characteristic polynomial (Fig. 2.6) has the maximum speed with virtually no oscillations and overshoot.

By changing the degree of removal of the poles of a closed system from the imaginary axis, one can obtain the required value of the system speed.

2.7 Modeling the processes of estimating the state vector of the system by the asymptotic observer.

Section 2.4 presents a technique for constructing an asymptotic observer and an algorithm for obtaining the numerical values of the feedback matrix L of the observer as a closed system. In the process of modeling an asymptotic observer for the system considered in the example of section 1.8, elements of the feedback matrix L were obtained for the binomial form of the characteristic polynomial, Butterworth and Bessel-Thomson (Fig. 2.7 - 2.9).

For each characteristic polynomial, the elements of matrix L are obtained for three values of the degree of distance of the system poles from the imaginary axis: $q = 10, 15, 20$.

The dynamics of the observer was estimated from the curve of the transient process of estimating the variable $x_1^*(t)$ of the system under nonzero initial conditions.

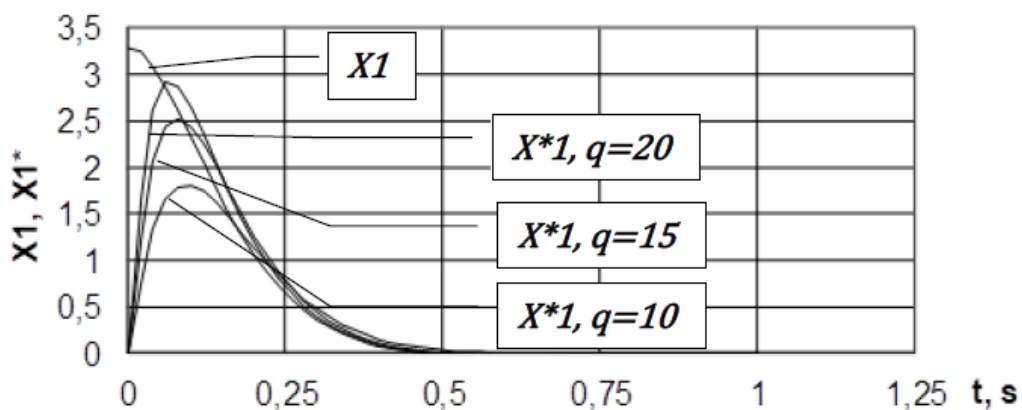

Fig. 2.7. Dynamics of observing process for the observer binomial characteristics polynomial

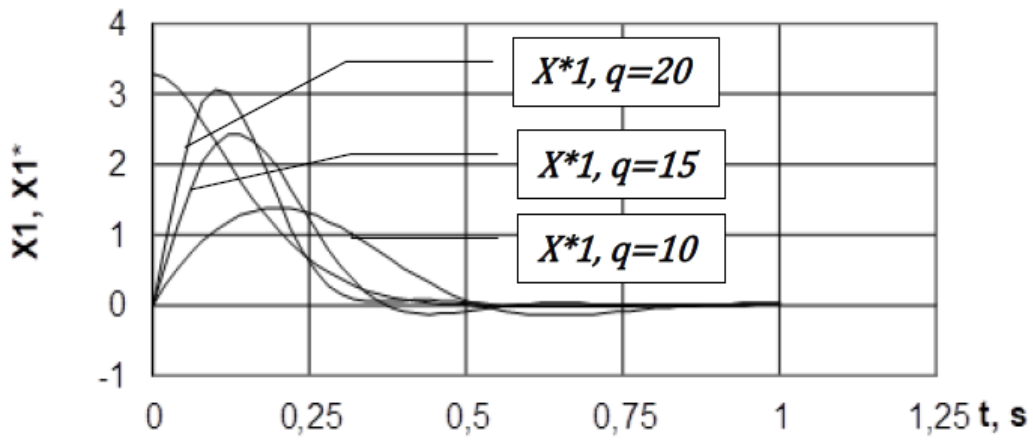

Fig. 2.8. Dynamics of observing process for the observer Butterworth characteristics polynomial

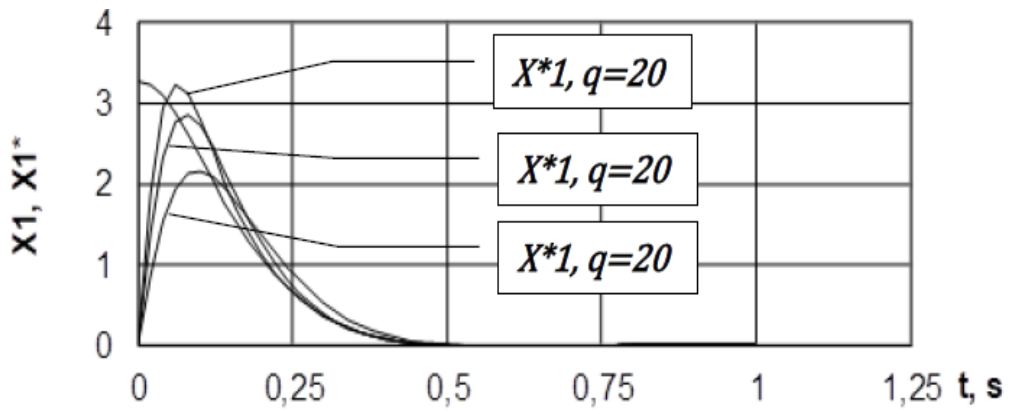

Fig. 2.9. Dynamics of observing process for the observer Bessel-Thomson characteristics polynomial

2.8 Modeling the process of estimating random disturbances acting on the control object.

To simulate the process of estimating random disturbances acting on the control object, the mathematical model of the extended observer (2.6) was used, the block diagram of which was shown in Fig. 2.3. When studying the dynamics of the process of estimating random perturbations, signals were applied to the input of the object, which were a combination of stepwise and linearly varying signals that correspond to real perturbations of the wave structure acting on the control object. The simulation results are shown in Fig. 2.10 -2.12.

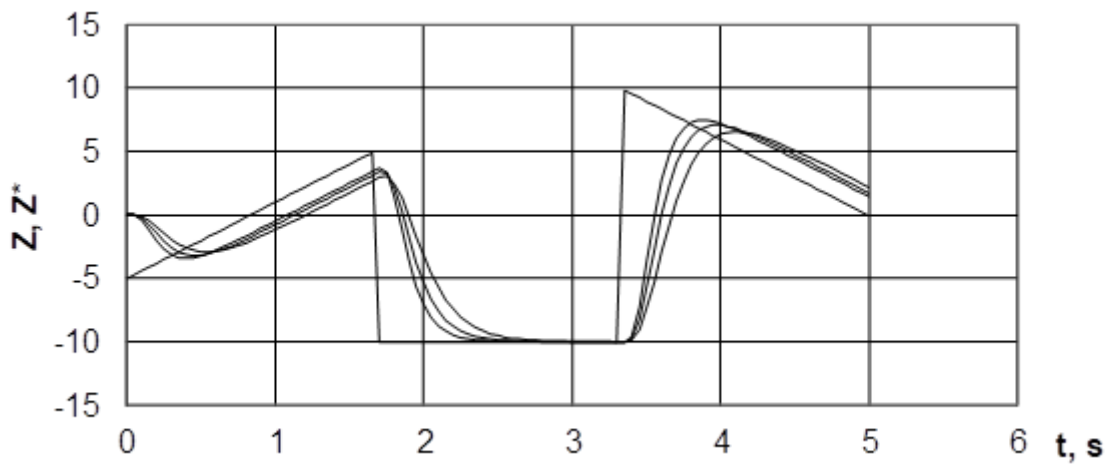

Fig. 2.10. Dynamics of the disturbance's estimation process for binomial observer characteristics polynomial

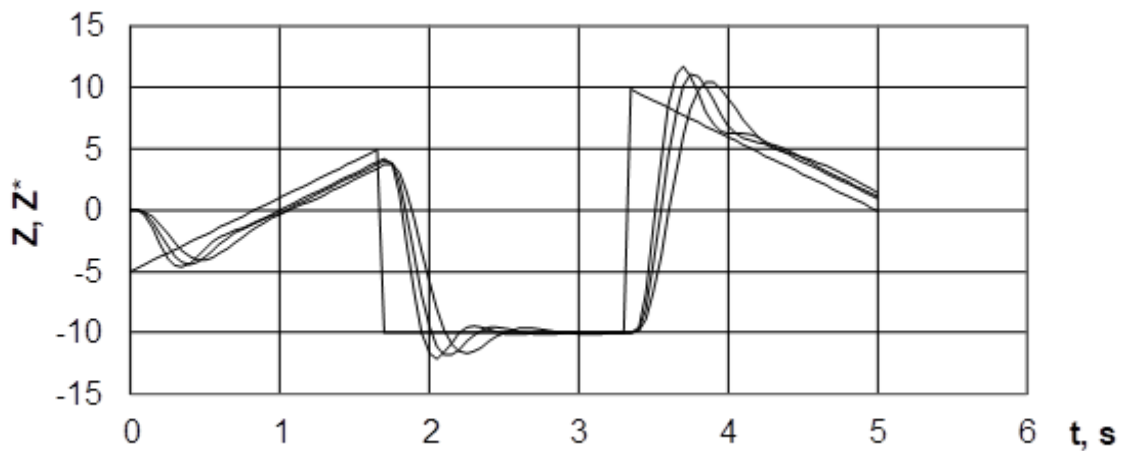

Fig. 2.11. Dynamics of the disturbance's estimation process for Butterworth observer characteristics polynomial

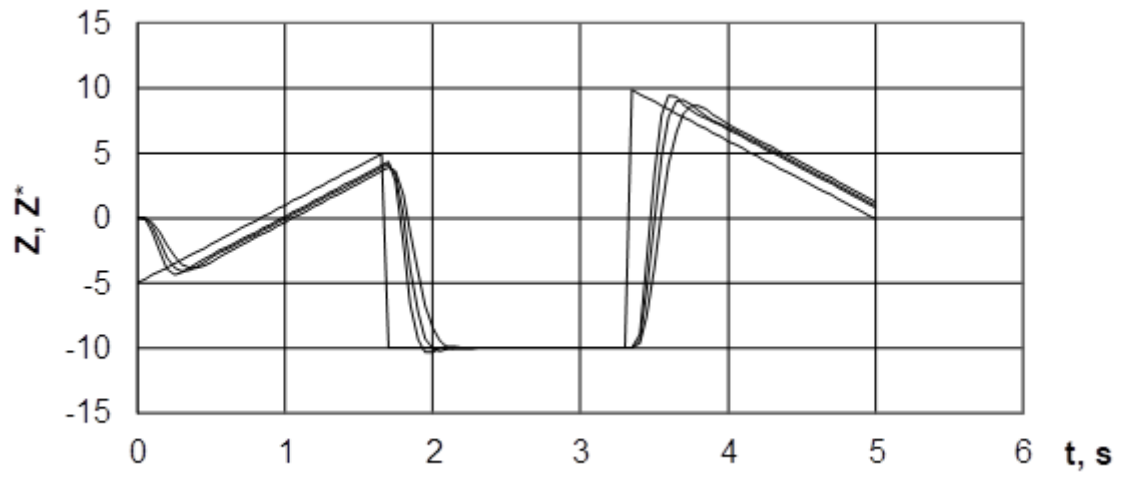

Fig. 2.12. Dynamics of the disturbance's estimation process for Bessel-Thomson observer characteristics polynomial

2.9 Simulation of the closed system operation under the action of random disturbances.

To simulate a system closed in terms of the state vector under the action of random disturbances, we will use the mathematical model of a closed system (Fig. 1.2) and the mathematical model of an extended observer (Fig. 2.3). The results of simulation of a closed system under the action of random disturbances are shown in Fig. 2.13 – 2.15.

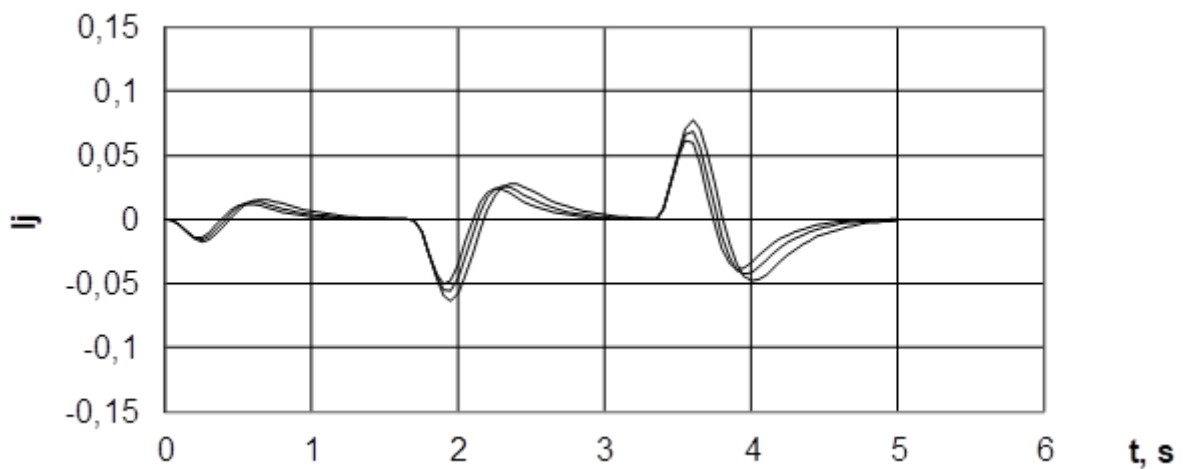

Fig. 2.13. Dynamics of closed system for binomial characteristics polynomial and the advanced observer

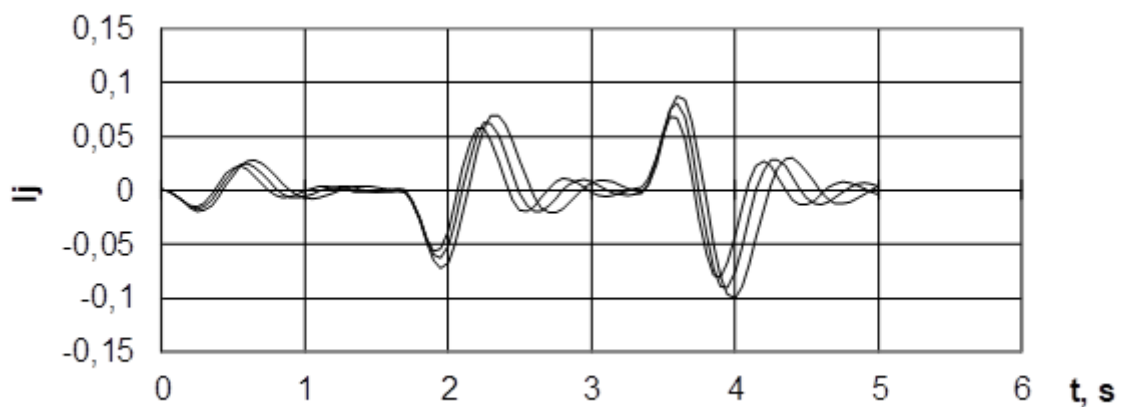

Fig. 2.13. Dynamics of closed system for Butterworth characteristics polynomial and the advanced observer

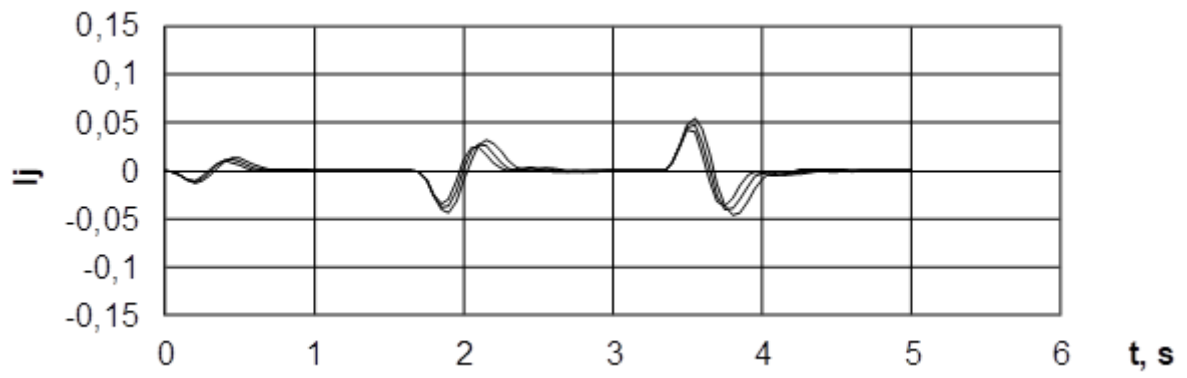

Fig. 2.13. Dynamics of closed system for Bessel-Thomson characteristics polynomial and the advanced observer

REFERENCES

1. Fleming, W.H. and Rishel, R.W. (2012). Deterministic and stochastic optimal control, volume 1. Springer Science & Business Media.
2. James, M. (2021). Optimal quantum control theory. *Annual Review of Control, Robotics, and Autonomous Systems*, 4, 343–367.
3. Lin, C., Ma, Y., and Sels, D. (2021). Optimal control for quantum metrology via Pontryagin's principle. *Physical Review A*, 103(5), 052607.
4. Werschnik, J. and Gross, E. (2007). Quantum optimal control theory. *Journal of Physics B: Atomic, Molecular and Optical Physics*, 40(18), R17
5. Ashyralyev A. Optimal control problems for impulsive systems with integral boundary conditions / A. Ashyralyev, Y.A. Sharifov // *Electronic Journal of Differential Equations*. 2013. - 2013. No. 80. P. 1–11.
6. Mekhtiyev M.F. Necessary optimality conditions of second order in classical sense in optimal control problems of three-point conditions / M.F. Mekhtiyev, Sh.I. Djabrailov, Y.A. Sharifov // *J. of Automation and Information Sciences*. - 2010. 42(3). P. 47–57.
7. Sharifov Y.A. On second-order necessary optimality conditions in the classical sense for systems with nonlocal conditions / Y.A. Sharifov, N.B. Mamedova // *Differential Equations*. - 2012. 48. No. 4. P. 614–617.21
8. Sharifov Y.A. Optimality conditions in problems of control over systems of impulsive differential equations with nonlocal boundary conditions / Sharifov Y.A. // *Ukrainian Mathematical Journal*. - 2012. 64. No. 6. P. 958–970.23